

## THE TRANSITION ZONE NEAR WRINKLES IN PULLED SPHERICAL MEMBRANES

AVINOAM LIBAI

Faculty of Aerospace Engineering—Technion, Israel Institute of Technology,  
Haifa 32000, Israel

(Received 20 May 1989; in revised form 12 November 1989)

**Abstract**—The unwrinkled transition zone between the rigid boundaries and the wrinkled portion of a spherical membrane subjected to a pulling force is analyzed. The strains are first assumed to be small, and two cases are considered: (a) a spherical membrane barrel pulled into a wrinkled cylinder and (b) a hemispherical membrane pulled into a wrinkled cone. It is shown that in both cases the angular size of the transition zone is  $O(\varepsilon)$ , where  $\varepsilon$  is the prevailing strain, rather than  $O(\sqrt{\varepsilon})$  as in the usual nonlinear membrane edge effect problem. Large rotations and substantial variations in the circumferential stresses and strains take place in this narrow zone. The extension to the case of “moderate” strains is then made for the spherical barrel, using a power series approach. It follows from the results that the size of the transition zone becomes  $O(\sqrt{\varepsilon})$  as the wrinkled region shrinks to zero. Finally, a complete large strain analysis of a partly wrinkled spherical barrel membrane is made. Included are both the transition zone and the interior wrinkled region. The analysis establishes the ranges of validity of the previous solutions and demonstrates the deterioration of the “edge effect”. A formula for the “wrinkle strain” in the interior is included. Interestingly, the deviation of the slope  $\bar{\alpha}$  of the deformed membrane from the wrinkled direction is shown to be always small, so that the problem can be assumed to be geometrically linear in  $\cot \bar{\alpha}$ , but materially nonlinear.

### INTRODUCTION

The partial wrinkling of thin, curved membranes is of both practical and theoretical interest. Yet, the mathematical problem posed by this phenomenon is formidable: in the general case it involves the solution of two systems of strongly nonlinear partial differential equations in abutting regions whose sizes and common boundaries are parts of the problem itself. Fortunately, in special cases of practical interest, the problems become simple enough, so that approximate solutions or special techniques become feasible. Steigmann (1989) and Steigmann and Pipkin (1989) have recently made extensive theoretical studies of the behavior of wrinkled and partly wrinkled membranes. Several examples were given, including the qualitative behavior of the partly wrinkled spherical membrane. Roddeman *et al.* (1987) developed a finite element method for the solution of partly wrinkled membranes. In his dissertation, Roddeman (1988) gives two numerical examples of a stretched hemispherical membrane, with and without pressure. A linear elastic material model with small strains was used in his examples. No transition zones appeared in the stretching example nor could they be detected, since the size of the elements was much larger than that of the transition zone.

The studies of Steigmann and Roddeman contain references to earlier work on the wrinkling of membranes. Additional references can be found in Libai and Simmonds (1988), Wu (1978) and others.

In this paper, a study is made of the regions adjacent to wrinkled zones in extensible spherical membranes which are axially pulled by edge loads and are otherwise unloaded. In such cases, the wrinkles cover most of the surface, but there exist unwrinkled regions near the rigid supports whose size may depend on the magnitude of the prevailing strains—as they become larger, the size of these “transition regions” increases. Two cases are considered in more detail: (a) the symmetrical pulling of a truncated spherical membrane (“barrel”) into a wrinkled cylinder (Fig. 1), and (b) a hemispherical membrane pulled at its apex into a wrinkled cone (Fig. 3). In both cases, Hooke’s Law is first assumed to hold

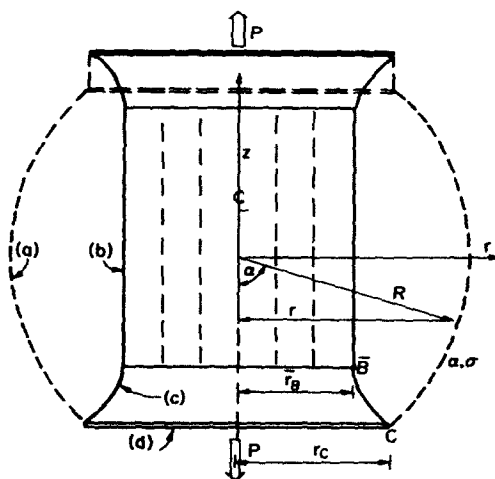

Fig. 1. Geometry of a spherical membrane barrel. (a) Spherical membrane, (b) wrinkled cylinder, (c) unwrinkled transition zone (exaggerated), (d) ring.

for small to moderate strains. The problem of case (a) is then solved for large strains using a Neo-Hookean material model (which merges with Hooke's Law for small strains). In all cases, the field equations of the transition zone are those of regular, unwrinkled nonlinear membrane theory. Tension field effects enter only implicitly by imposing continuity with the adjacent wrinkled region, at a location which constitutes a part of the problem.

The approach to the solution is mainly analytical. It is based on the fact that a sufficient number of conditions exists at the (unknown) interior boundary between the transition zone and wrinkled interior so as to transform the problem from a *two-point boundary value problem* to an *initial value problem* which is much easier to handle. Power series and asymptotic solutions are developed for the case of small moderate strains. In the case of large strains, a simple forward integration procedure is used to solve the nonlinear ordinary differential equations over a wide range of parameters.

Once the transition zone is established, the properties of the wrinkled interior may be obtained without difficulty. Those of the large strain case of the spherical barrel are given as an example. Included are the extensions, stresses, wrinkle strain and gross properties (deformed radius and height).

#### A SPHERICAL BARREL PULLED INTO A WRINKLED CYLINDER

Consider a truncated spherical membrane which is attached to two rigid rings located along two parallel circles at equal distances above and below its equator. The portion of the membrane contained between the rings constitutes the "spherical barrel" (Fig. 1). The barrel is pulled apart by two equal and opposite axial forces applied through the rings.

The membrane is assumed to be unable to sustain compressive stresses (this idealizes the behavior of very thin shells which virtually lack bending rigidity). Hence, a "tension field" develops over most of the deformed membrane. As shown by Zak (1982), the wrinkly pseudosurface† must be ruled, and symmetry dictates it to be a circular cylinder. If the membrane is further assumed to be inextensional, then the cylinder would cover the entire region between the two rings. However, if effects of extensionality are taken into account, then some region near the supporting rings remain unwrinkled. This has been pointed out by Steigmann and Pipkin (1989), who also gave a qualitative estimate for the size of the unwrinkled region.

† This is a term used by some authors to denote the smooth "average" surface which spans a wrinkled region; see Wu (1978) and Libai and Simmonds (1988). Other terms such as "generalized surface" have also been used. See Steigmann (1989) for an additional discussion and literature.

It will be first assumed that the strains are small compared with unity and that Hooke's law applies in the form :

$$e_\sigma = \frac{1}{Eh}(N_\sigma - \nu N_\theta), \quad e_\theta = \frac{1}{Eh}(N_\theta - \nu N_\sigma) \tag{1}$$

where  $E$  is Young's modulus,  $\nu$  is Poisson's ratio,  $h$  is the initial shell thickness,  $N_\sigma$ ,  $N_\theta$  are the membrane forces per unit undeformed length (in the corresponding directions) and  $e_\sigma$ ,  $e_\theta$  are the corresponding strains. Also,  $\sigma$ ,  $\theta$  are the meridional and circumferential directions, respectively. The strains are related to the geometry through :

$$e_\sigma = \frac{d\bar{\sigma}}{d\sigma} - 1; \quad e_\theta = \frac{\bar{r}}{r} - 1 \tag{2}$$

where  $\sigma$  denotes arc length ( $\sigma = R\alpha$ ),  $r$  denotes radial distance to the axis and values in the deformed membrane are denoted by top bars.

QUALITATIVE ANALYSIS

At the support C (see Fig. 2)  $\bar{r} = r$ , so that  $e_\theta = 0$  and  $N_\theta = \nu N_\sigma$ . It follows that  $N_\theta$  is positive at C (since  $N_\sigma$  is always positive due to the pulling). Continuity of  $\bar{r}(\sigma)$  and  $r(\sigma)$  imply continuity of  $e_\theta$ . Hence, there exists some region near C where  $N_\theta$  is positive. The membrane is not wrinkled in this region. As we get away from the support,  $\bar{r}/r$  decreases, till a point B is reached where  $N_\theta$  vanishes. At this point, the wrinkled region starts. Denoting by  $\bar{\alpha}$  the angle that the deformed membrane makes with the positive  $r$  direction, then angular continuity at B requires that  $\bar{\alpha}_B = \pi/2$ .

The shape of the unwrinkled region CB can be envisaged, qualitatively, by considering the equation of membrane equilibrium in the direction normal to the deformed surface. Using, for example, eqn (V.T.30) of Libai and Simmonds (1988), we find that, since the two membrane forces are positive and there is no pressure, the Gaussian curvature  $\bar{K}$  of the deformed membrane must be negative. Together with  $\bar{\alpha}_B = \pi/2$ , this dictates the shape as seen in Figs 1 and 2.

Noting that the Gaussian curvature of the undeformed membrane is  $K = 1/R^2$ , we find that  $\Delta K = \bar{K} - K \leq (-1/R^2)$ . Substituting into the Gauss compatibility equation of Shell theory (which relates  $\Delta K$  to the second partial derivatives of the strains), we find that :

$$|e_{\theta,zz}| = O(1) \tag{3}$$

(note that  $e_\theta$  is the dominant quantity in the equation and we switched to  $\alpha$  as the independent variable). Since the strains are assumed to be small, it follows that their derivatives in the CB region must be large, which is typical of an "edge effect" behavior.

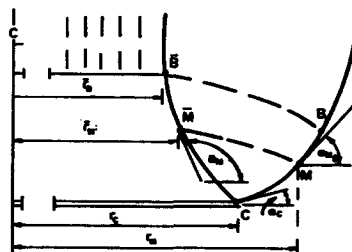

Fig. 2. Geometry near the supporting ring and displacement of a material point M.

## FIELD EQUATIONS

In an axisymmetric setting, the small strain compatibility equation, taken from Libai and Simmonds (1988) eqn (V.M.3), with  $g \equiv 0$  and  $e_\sigma \ll 1$ , is:

$$(re_\theta)_{,\sigma} - e_\sigma \cos \alpha = \cos \bar{\alpha} - \cos \alpha. \quad (4)$$

In this equation,  $(\cos \bar{\alpha} - \cos \alpha)$  is of order unity. This is compensated for by the large strain gradient of the first term on the left. The second term is, obviously, of lesser importance but is retained for completeness. Substitution of (1) and use of the relationship:

$$r_{,\sigma} = \cos \alpha \quad (5)$$

yields the stress form of the compatibility eqn (4):

$$(rN_\theta)_{,\sigma} - N_\sigma \cos \bar{\alpha} = Eh(\cos \bar{\alpha} - \cos \alpha). \quad (6)$$

Equilibrium equations for the membrane yield expressions for  $N_\sigma$  and  $N_\theta$ :

$$N_\sigma = \frac{P}{2\pi r \sin \bar{\alpha}} \quad (7)$$

$$N_\theta = (rN_\sigma \cos \bar{\alpha})_{,\sigma} = \frac{P}{2\pi} (\cot \bar{\alpha})_{,\sigma}. \quad (8)$$

Substitution of (7) and (8) into (6), leads to a second-order differential equation in  $\bar{\alpha}$ :

$$[r(\cos \bar{\alpha})_{,\sigma}]_{,\sigma} - \frac{1}{r} \cot \bar{\alpha} = \frac{2\pi Eh}{P} (\cos \bar{\alpha} - \cos \alpha) \quad (9)$$

which is valid for all unwrinkled axisymmetric membranes regardless of shape. In the specific case of a spherical membrane, substitution of  $\sigma = R\alpha$  and  $r = R \sin \alpha$  yields:

$$(\sin \alpha y_{,\alpha})_{,\alpha} - \frac{1}{\sin \alpha} y = \varepsilon^{-1} \left( \frac{y}{\sqrt{1+y^2}} - \cos \alpha \right) \quad (10)$$

where

$$\varepsilon = \frac{P}{2\pi REh} \quad (11)$$

is a small quantity of the order of the prevailing strains, and:

$$y = \cot \bar{\alpha}. \quad (12)$$

## BOUNDARY CONDITIONS

(a) Exterior boundary ( $\alpha = \alpha_c$ ): this boundary is fixed in space. Hence:

$$\bar{r}_c = r_c \quad \text{or} \quad e_\theta = 0(\alpha = \alpha_c). \quad (13)$$

(b) Interior boundary ( $\alpha = \alpha_B$ ): conditions at this point are a consequence of continuity and equilibrium requirements between the unwrinkled and wrinkled portions of the membrane.

(1) The slope is continuous. This results from local equilibrium requirements which prohibit the formation of angular jumps across boundaries which transmit normal forces. For the case at hand, the wrinkled membrane is a cylinder. This yields :

$$\bar{\alpha}_B = \pi/2(\alpha = \alpha_B). \tag{14}$$

(2) The position vector (including radial distances) is continuous at  $\alpha_B$ . Consequently,  $e_\theta$  is continuous (but not its derivatives) and the “wrinkle strain” (to be discussed later) vanishes there.

(3) The circumferential stress resultant vanishes (by definition) :

$$N_\theta = 0(\alpha = \alpha_B). \tag{15}$$

Although  $N_\theta$  is continuous across the boundary, its derivatives are not.

(4) The meridional stress resultant (per unit undeformed circumferential length) is continuous across the boundary. Its value is determined by eqn (7).

The requirements set above are valid for large as well as small strain formulations. They can be translated into three conditions on the differential eqn (10) as follows: eqn (13), together with (1), (7) and (8) yield the condition :

$$\sin \alpha y_{,x} = v\sqrt{1+y^2}(\alpha = \alpha_c). \tag{16}$$

Equations (14) and (15) when substituted into (8) yield the conditions :

$$y = y_{,x} = 0(\alpha = \alpha_B). \tag{17a,b}$$

The three requirements are needed to determine the solution *and the size of the interval* ( $\alpha_B - \alpha_c$ ).

SOLUTION

The availability of *two* conditions at ( $\alpha_B$ ) makes it possible to treat (10)+(17a,b) as an initial value problem for a second-order quasilinear ordinary differential equation. A solution can start from point B and proceed into the region BC. The integration stops when condition (16) is met, and the size of the interval is thus determined.

A standard numerical scheme which would utilize an available computer (or even a programmable calculator) equation solver, can be employed. As data, the given value of  $\epsilon$  and an assumed value for  $\alpha_B$  should be used. The approximation  $\alpha_B \approx \alpha_c$  can be made at this stage since, as will be seen later, the difference is quite small. For the integration, it is advisable to stretch the interval to order unity (or, equivalently, choose sufficiently small integration steps). The stretching parameter to be used is not obvious because of the strong effects of (16) on the size of the interval so that the apparently obvious stretching  $\eta = \epsilon^{-1/2}(\alpha_B - \alpha)$  might not be the correct one. The need for an approximate (but fairly accurate) analytical solution is apparent and we proceed to do so by a *power series* expansion about B.

The derivatives of all orders can be obtained from eqn (10) and initial conditions (17). Their values at  $\alpha_B$  are :

$$y^{(B)} = 0, \quad y'_{,x}{}^{(B)} = 0, \quad y''_{,\alpha\alpha}{}^{(B)} = -\epsilon^{-1} \cot \alpha_B, \quad y'''_{,\alpha\alpha\alpha}{}^{(B)} = \epsilon^{-1}(1 + 2 \cot^2 \alpha_B),$$

$$y^{(B)}_{,\alpha\alpha\alpha\alpha} = -\epsilon^{-2} \frac{\cot \alpha_B}{\sin \alpha_B} \left( 1 + \epsilon \frac{6 + \cos^2 \alpha_B}{\sin \alpha_B} \right) \tag{18}$$

and so forth. The Taylor series expansion at  $\alpha_B$  is :

$$y = -\frac{1}{2} \cot \alpha_B u^2 - \frac{\sqrt{\varepsilon}}{6} (1 + 2 \cot^2 \alpha_B) u^3 - \frac{1}{24} \frac{\cot \alpha_B}{\sin \alpha_B} \left( 1 + \frac{6 + \cos^2 \alpha_B}{\sin \alpha_B} \varepsilon \right) u^4 + \dots \quad (19)$$

where  $u = \varepsilon^{-1/2}(\alpha_B - \alpha)$ ;  $u_c = \varepsilon^{-1/2}(\alpha_B - \alpha_c)$ . Note that  $\alpha_B$  is a regular point of (10) so that the expansion should be valid at some neighborhood of B, such that  $\alpha_B - \alpha \geq 0$ . It should be possible now to set up condition (16) at  $\alpha = \alpha_c$ , and calculate  $(\alpha_B - \alpha_c)$ . The resulting transcendental equation is rather cumbersome. We therefore make the sweeping approximation of retaining only the first term in (19):

$$y = -\frac{1}{2} \cot \alpha_B u^2 + R. \quad (20)$$

The error ( $R$ ) made in truncating the series will be evaluated *a posteriori*. Putting (20) into (16), we get a quadratic equation for  $u_c$ :

$$\sin^2 \alpha_c \cot^2 \alpha_B u_c^2 = \varepsilon v^2 (1 + \frac{1}{4} \cot^2 \alpha_B u_c^4). \quad (21)$$

It follows from (21) that  $u_c = O(\sqrt{\varepsilon})$  and therefore  $\alpha_c - \alpha_B = O(\varepsilon)$ . Omitting all higher order terms in  $\varepsilon$ , we find:

$$(\alpha_B - \alpha_c) = \frac{v\varepsilon}{\cos \alpha_c} + O(\varepsilon^2). \quad (22)$$

Also, to the same order in  $\varepsilon$ , we can replace  $\alpha_B$  with  $\alpha_c$  in (20). Going back to (19) we find that all the truncated terms are  $O(\varepsilon^2)$ . Hence we are justified in writing:

$$y = \frac{1}{2} \cot \alpha_c \left( \frac{\alpha - \alpha_B}{\sqrt{\varepsilon}} \right)^2 + O(\varepsilon^2). \quad (23)$$

To calculate the rotation at C, we put  $\alpha = \alpha_c$  in (23) and use (22). The result is:

$$\cot \bar{\alpha}_c = -\frac{v^2 \varepsilon}{\sin 2\alpha_c} + O(\varepsilon^2).$$

This completes the approximate solution. We can draw from the results four important conclusions, as follows.

- (a) The size of the unwrinkled zone is  $O(\varepsilon) = O(e_\sigma)$ . This contrasts with the more common situations in nonlinear membrane theory, where boundary zones of size  $O(\sqrt{\varepsilon})$  are encountered. Its very narrowness has led to its omission by some authors. This peculiar behavior which is related to the effects of condition (16) also determines the stretching which should be done for numerical calculations:  $\eta = \varepsilon^{-1}(\alpha_B - \alpha)$ .
- (b) The deformed membrane is almost vertical. The rotation  $\beta$  at C is given by:

$$\beta_c = \pi/2 + \arctan \left( \frac{v^2 \varepsilon}{\sin 2\alpha_c} \right) - \alpha_c. \quad (24)$$

It is of order unity.

- (c) A circumferential membrane force  $N_\theta$  exists in the transition zone. It increases rapidly from zero at B to  $vN_{\sigma_c}$  at C, so that:

$$N_{\theta_c} = \frac{vP}{2\pi R \sin \alpha_c \sin \bar{\alpha}_c}. \quad (25)$$

- (d) As  $\alpha_B \rightarrow \pi/2$ , the asymptotic solution breaks down, and more terms in the series should be taken. This will be done at a later stage.

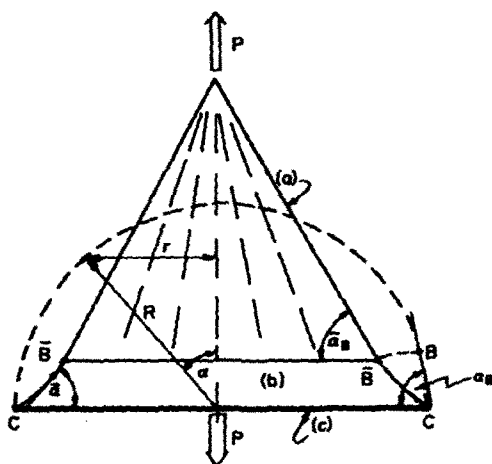

Fig. 3. Deformed and undeformed geometries of a hemisphere loaded at its apex. (a) Wrinkled cone, (b) transition region (exaggerated size) and (c) ring.

A HEMISPHERICAL MEMBRANE PULLED AT ITS APEX

The approach to the solution of the spherical membrane barrel problem lends itself to extension to other cases of membrane pulling. Consider, for example, a hemispherical membrane which is pulled at its apex by a force  $P$ . This problem was discussed in Libai and Simmonds (1988) for the inextensional case (see pp. 284–285, there). It was shown that the psuedosurface is a right circular cone based at the equatorial support. Roddeman (1988) used finite elements to obtain a conical solution for an extensional membrane. His elements were, however, too large to be able to detect the transition zone near the supports which is being studied here. Compared to the spherical barrel, the differential equation is the same, but the boundary data are somewhat different: at the support,  $\alpha_c = \pi/2$ , and at the transition point B (see Fig. 3), the slope of the cone is given by the equation:

$$\cos \bar{\alpha}_B = (\sin \alpha_B - \epsilon v \sin \bar{\alpha}_B^{-1})(\alpha_B + \Delta L/R)^{-1} \tag{26}$$

where the elongation of the pseudocone is denoted by  $\Delta L$ . If we omit local effects at the apex†, then  $\Delta L = RO(\epsilon)$ . Neglecting terms  $O(\epsilon)$  in (26) we have:

$$\cos \bar{\alpha}_B \approx \frac{\sin \alpha_B}{\alpha_B} + O(\epsilon). \tag{26a}$$

As we shall see later,  $\alpha_B = (\pi/2) - O(\epsilon)$ . Hence:

$$\cos \bar{\alpha}_B \approx (2/\pi) + O(\epsilon), \quad \bar{\alpha}_B = 50.46^\circ \dots + O(\epsilon). \tag{26b}$$

As before, the solution to the equation is obtained by expanding it as a Taylor series about B. The coefficients of the series are:

$$\begin{aligned} y^{(B)} &= \cot \bar{\alpha}_B, \quad y_{,\alpha}^{(B)} = 0, \quad y_{,\alpha\alpha}^{(B)} = \csc^2 \alpha_B \cot \bar{\alpha}_B + \epsilon^{-1} \csc \alpha_B (\cos \bar{\alpha}_B - \cos \alpha_B) = O(\epsilon^{-1}) \\ y_{,\alpha\alpha\alpha}^{(B)} &= \epsilon^{-1} [1 - 2 \cos \alpha_B \csc^2 \alpha_B (\cos \bar{\alpha}_B - \cos \alpha_B)] - 3 \cos \alpha_B \csc^3 \alpha_B \cot \bar{\alpha}_B = O(\epsilon^{-1}) \\ y_{,\alpha\alpha\alpha\alpha}^{(B)} &= \epsilon^{-1} [y_{,\alpha\alpha}^{(B)} \sin^3 \bar{\alpha}_B + \cos \alpha] + (3 + \csc^2 \alpha_B) y_{,\alpha\alpha}^{(B)} - 3 \cot \alpha_B y_{,\alpha\alpha\alpha}^{(B)} \\ &\quad - \csc \alpha_B (\cos \alpha \csc^2 \alpha)_{,\alpha}^{(B)} y^{(B)} = O(\epsilon^{-2}). \end{aligned} \tag{27}$$

† Large strains exist near the apex due to stress singularities. We avoid them by assuming that the membrane near the apex is made from inextensional material.

We retain the first two terms in the Taylor series for  $y$ :

$$y = y^{(B)} + \frac{1}{2}y''^{(B)}(\alpha - \alpha_B)^2 + R. \tag{28}$$

We shall demonstrate later on that  $R$  is  $O(\epsilon)$  compared with the retained terms. For the present case, the condition at  $c$  is:

$$y'_{,x}^{(c)} = v[1 + (y^{(c)})^2]^{1/2} \quad (\alpha = \pi/2) \tag{29}$$

which becomes upon substitution and squaring:

$$(y''_{,xx}^{(B)})^2 (\alpha_c - \alpha_B)^2 = v^2 \{1 + [y^{(B)} + \frac{1}{2}y''_{,xx}^{(B)}(\alpha_c - \alpha_B)^2]^2\}. \tag{30}$$

This is an equation for  $(\alpha_c - \alpha_B)$ . Using (27) for  $y''_{,xx}^{(B)}$  we find that:

$$(\alpha_c - \alpha_B) = \frac{2v\epsilon}{\sin 2\tilde{\alpha}_B} + O(\epsilon^2). \tag{31}$$

Combining (31) with (27), we find that the remainder  $R$  in the Taylor expansion (28) is, indeed,  $O(\epsilon^2)$  and can be neglected compared with the retained  $O(\epsilon)$  term. Another consequence of (31) is that  $\sin \alpha_B = 1 - O(\epsilon^2)$ ,  $\cos \alpha_B = O(\epsilon)$ . Thus we have for (28):

$$\cot \tilde{\alpha} = \cot \tilde{\alpha}_B + \cos \tilde{\alpha}_B \left( \frac{\alpha - \alpha_B}{\sqrt{\epsilon}} \right)^2 + O(\epsilon^2). \tag{32}$$

The results are qualitatively similar to those of the spherical barrel. In particular, the size of the transition zone is again  $O(\epsilon)$  and its effects can be omitted when the strains are small.

AN EXTENSION TO "MODERATE" STRAINS—SPHERICAL BARREL

As the strains increase, the asymptotic approximations as well as Hooke's Law (1) lose their accuracy. Nevertheless, it is possible to get an estimate of the behavior at moderate strains (say,  $\epsilon \sim 0.01-0.2$ ) by using Hooke's law as an approximation, while taking more terms in the Taylor series expansion about B. Considering the spherical barrel problem, terms up to 4th power in  $(\alpha_B - \alpha)$  are given by eqns (19), and the truncated terms are of the order of  $\epsilon^3$ .

A simple numerical procedure of inserting increasing values of  $u$  into (19), until condition (16) is met (or exceeded), was performed. Values of  $(\alpha_B - \alpha_c)$  and  $\tilde{\alpha}_c$  were obtained for several values of  $\alpha_B$  and  $\epsilon$ , with a Poisson's ratio of  $\nu = 0.5$ . Results for  $\alpha_B = 60^\circ$  are compared with the other methods in Table 1. Analysis of the comparisons is deferred to a later section.

Table 1. Transition zone size  $(\alpha_B - \alpha_c)$  and edge slope of deformed membrane  $\tilde{\alpha}_c$  as functions of  $\epsilon$ , for  $\alpha_B = 60^\circ$  and  $\nu = 0.5$  (results are in degrees). (a) Asymptotic formulas. (b) Series approach. (c) Large strain results, Neo-Hookean material ( $E = 6C$ )

$\epsilon$	$(\alpha_B - \alpha_c)^\circ$			$\tilde{\alpha}_c^\circ - 90^\circ$		
	(a)	(b)	(c)	(a)	(b)	(c)
0.01	0.57	0.57	0.57	0.165	0.165	0.17
0.05	2.86	2.75	2.79	0.83	0.80	0.81
0.1	5.73	5.27	5.34	1.65	1.54	1.58
0.2	11.46	9.85	10.06	3.30	2.93	3.03
0.3	17.19	14.09	14.07	4.95	4.32	4.20
0.5	28.65	22.63	20.31	8.21	7.79	5.35
0.7	40.11	33.29	24.49	11.42	14.37	5.17



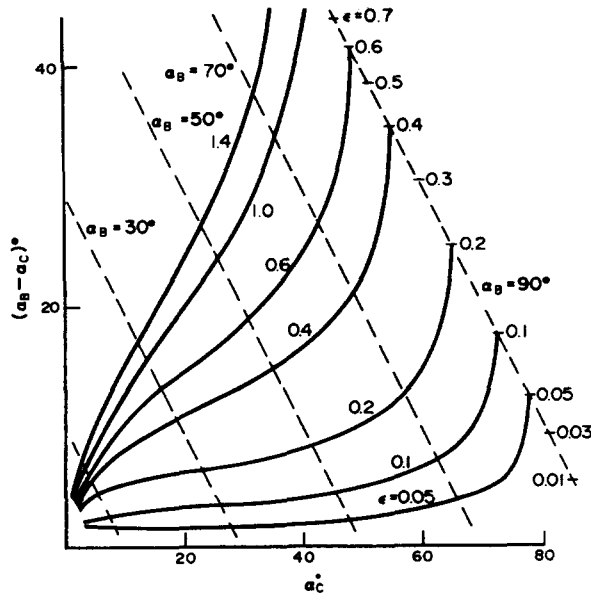

Fig. 4. Transition-zone size  $(\alpha_B - \alpha_c)$  as function of the edge coordinate  $\alpha_c$  and prevailing strain  $\epsilon$  in a Neo-Hookean spherical membrane barrel.

Of particular interest is the behavior near  $\alpha_B = 90^\circ$ , where the asymptotic formulae (22) and (23) break down. Using (19) and putting  $\alpha_B = \pi/2$ , the series solution becomes :

$$y = -(6\epsilon)^{-1}(\alpha_B - \alpha)^3 + O(\sqrt{\epsilon}u^5) \tag{33}$$

with boundary condition at  $\alpha_c$  :

$$(\alpha_B - \alpha_c)^2 \cos(\alpha_B - \alpha_c) = 2v\epsilon[1 + (6\epsilon)^{-2}(\alpha_B - \alpha_c)^6]^{1/2} \tag{34}$$

To lowest order in  $\epsilon$ , the results are :

$$(\alpha_B - \alpha_c) = \sqrt{2v\epsilon} + O(\epsilon^{3/2}); \quad \cot \bar{\alpha}_c = -\frac{v}{3}\sqrt{2v\epsilon} + O(\epsilon^{3/2}). \tag{35}$$

We have thus shown that as  $\alpha_B \rightarrow \pi/2$ , the size of the transition zone changes its order of magnitude from  $O(\epsilon)$  to  $O(\sqrt{\epsilon})$ . See, for example, Fig. 4. This increase goes together with the *disappearance* of the wrinkled region (which is implied by  $\alpha_B = \pi/2$ ). It may be concluded that, at least for this case, the shrinking of the wrinkled region entails the return of the "edge effect" region to its normal size of  $O(\sqrt{\epsilon})$ .

LARGE STRAIN ANALYSIS OF A NEO-HOOKEAN SPHERICAL BARREL MEMBRANE

(a) *The transition zone*

In the case of large strains  $\epsilon = O(1)$ , the narrow transition region is obliterated and recourse must be made to numerical or power series methods. Appropriate constitutive relations, such as those listed on p. 390 of Libai and Simmonds (1988) should be employed together with the exact compatibility equation :

$$(\lambda_\theta \sin \alpha)_{,x} = \lambda_0 \cos \bar{\alpha}. \tag{36}$$

In the above, the extensions  $\lambda_\theta$  and  $\lambda_\sigma$  are defined by :

$$\lambda_\theta = 1 + e_\theta; \quad \lambda_\sigma = 1 + e_\sigma. \tag{37}$$

The process is simplest if a complementary energy function  $\Psi(N_\sigma, N_\theta)$  is available, such that:

$$e_\gamma = \Psi_{,N_\gamma}. \tag{38}$$

Substitution of (38) into (36), together with the use of (7) and (8), yield again a second-order equation in the variable  $y = \cot \bar{\alpha}$ , with the initial conditions  $y^{(B)} = y_{,x}^{(B)} = 0$ . Solution by integration or power series expansion proceeds until the condition  $\Psi_{,N_\theta} = 0$  is met, thus determining  $\alpha_c$  and the size of the transition zone.

The strain energy function  $\Phi$  and the corresponding constitutive relations for a Neo-Hookean membrane are given (for the present case) by:

$$\Phi = Ch(\lambda_\sigma^2 + \lambda_\theta^2 + \lambda_3^2 - 3) \tag{39a}$$

$$N_\sigma = \Phi_{,\lambda_\sigma} = 2Ch\lambda_\sigma^{-1}(\lambda_\sigma^2 - \lambda_3^2) \tag{39b}$$

$$N_\theta = \Phi_{,\lambda_\theta} = 2Ch\lambda_\theta^{-1}(\lambda_\theta^2 - \lambda_3^2) \tag{39c}$$

where

$$\lambda_3 = (\lambda_\sigma \lambda_\theta)^{-1}. \tag{39d}$$

To ensure reduction to Hooke's Law for small strains, take:

$$E = 6C; \quad \nu = 0.5. \tag{39e}$$

A complete inversion of (39), in order to obtain  $\Psi$ , leads to a cumbersome equation and is not actually needed. Instead, a partial inversion is effected by subtracting (39c) from (39b), yielding:

$$\lambda_\sigma = \left(\frac{N_\sigma}{4Ch}\right) + \left[\left(\frac{N_\sigma}{4Ch}\right)^2 + \lambda_\theta^2 - \left(\frac{N_\theta}{2Ch}\right)\lambda_\theta\right]^{1/2}. \tag{40}$$

This expression may replace (39b) in the constitutive relations and can be useful for numerical algorithms. The system of equations to be solved consists of eqns (36), (39c) and (40), with  $N_\sigma$  and  $N_\theta$  defined in terms of  $\bar{\alpha}$  by (7) and (8). The unknowns are  $\bar{\alpha}$ ,  $\lambda_\theta$ ,  $\lambda_\sigma$ . The solution process consists of a stepwise integration in  $\alpha$  from an assumed value of  $\alpha_B$ . At the  $n$ th step, eqn (36) is stepwise integrated to obtain  $\lambda_\theta^{n+1}$ , then eqn (39c), with  $N_\theta$  expressed in terms of  $(\cot \bar{\alpha})_{,x}$  through (8), is stepwise integrated to obtain  $(\cot \bar{\alpha})^{n+1}$  and finally, eqn (40) (or 39b) is solved for  $\lambda_\sigma^{n+1}$ , in which (7) and (39c) are used to express  $N_\sigma$  and  $N_\theta$ . Runge-Kutta type iteration loops can be used to improve accuracy.

The initial conditions at  $\alpha = \alpha_B$  are:  $\cot \bar{\alpha} = 0$  and  $N_\theta = 0$ . Inserting into (39b,c) the result is a cubic equation in  $\lambda_\sigma^{(B)}$ :

$$(\lambda_\sigma^{(B)})^3 - 3\varepsilon \csc \alpha_B (\lambda_\sigma^{(B)})^2 = 1. \tag{41a}$$

Letting  $q = 0.5 + (\varepsilon \csc \alpha_B)^3$ , its solution is:

$$\lambda_\sigma^{(B)} = [q + (q - 0.25)^{1/2}]^{1/3} + [q - (q - 0.25)^{1/2}]^{1/3} + \varepsilon \csc \alpha_B \tag{41b}$$

$$\lambda_\theta^{(B)} = (\lambda_\sigma^{(B)})^{-1/2}. \tag{41c}$$

The integration proceeds until the condition  $\lambda_\theta = 1$  is met or exceeded. This establishes  $\alpha_c$  and  $\bar{\alpha}_c$ .

Table 2. Edge slope of the deformed membrane  $\bar{\alpha}_c$  (in degrees) for the no-wrinkle case ( $\alpha_B = 90^\circ$ ), and various values of  $\varepsilon$ . (b) Series approach [Eqn. (35)]. (c) Large strain Neo-Hookean material

$\varepsilon$		0.05	0.1	0.3	0.5	0.57	0.7	1.0	1.4
$\bar{\alpha}_c - 90^\circ$	(b)	2.13	3.02	5.22	6.72	7.17	7.94	9.46	11.16
	(c)	2.17	2.99	5.50	6.59	6.66	6.48	5.53	4.35

(b) *The wrinkled region*

This region forms a pseudocylinder of radius and height given by:

$$\bar{r} = \bar{r}_B = R \sin \alpha_B [\lambda_\sigma^{(B)}]^{-1/2}, \quad H = 2R \int_{\alpha_B}^{\pi/2} \lambda_\sigma(\alpha) \, d\alpha.$$

It extends over the angular region  $\alpha_B \leq \alpha \leq \pi - \alpha_B$ . The extensions  $\lambda_\sigma(\alpha)$  and  $\lambda_\theta(\alpha)$  are determined from (41b,c), with  $\alpha$  replacing  $\alpha_B$ . The nonzero stress resultant per unit undeformed length is  $N_\sigma = (P/2\pi R) \csc \alpha$  and the corresponding Cauchy stress resultant is  $T_\sigma = N_\sigma \lambda_\sigma^{1/2}$ . The local quantities do not depend on the transition zone solution, but the gross quantities  $\bar{r}$ ,  $H$  do depend on it (through  $\alpha_B$ ).

It should be noted that, due to wrinkling,  $\lambda_\theta(\alpha)$  is not a strain measure of the pseudo-surface and therefore does not represent the ratio of radial distances. An "apparent" extension  $\bar{\lambda}_\theta(\alpha) = \bar{r}/r$  can be defined to measure this ratio. The difference between the apparent and true extensions is the "wrinkle strain". In the present case

$$w_\theta(\alpha) = \bar{\lambda}_\theta(\alpha) - \lambda_\theta(\alpha) = \frac{\sin \alpha_B}{\sin \alpha} [\lambda_\sigma^{(B)}]^{-1/2} - [\lambda_\sigma(\alpha)]^{-1/2}$$

where both  $\lambda_\sigma^{(B)}$  and  $\lambda_\sigma(\alpha)$  are obtained from (41b) for the appropriate  $\alpha$ . Obviously,  $w_\theta(\alpha_B) = 0$ .

As observed by Wu (1978), the need for introducing the "wrinkle strain" as an additional variable in wrinkled membranes follows from the concurrent introduction of the additional constraint equation  $N_\theta = 0$ . Consequently, wrinkled and unwrinkled regions are such that in the interior of the first  $N_\theta = 0$ ,  $w_\theta \neq 0$ , in the interior of the second  $N_\theta \neq 0$ ,  $w_\theta = 0$ , while on their common boundary  $N_\theta = w_\theta = 0$ . Obviously,  $w_\theta$  takes no part in the analysis of the (unwrinkled) transition region since it vanishes in its interior and boundaries. In the present case it is even not needed for the analysis of the wrinkled region and may be calculated (if desired) after the completion of the analysis.

RESULTS AND DISCUSSION

The large strain transition zone equations† were solved over a wide range of  $\varepsilon$  and  $\alpha_B$ . Results for the size of the transition zone ( $\alpha_B - \alpha_c$ ) are plotted in Fig. 4 against  $\alpha_c$  (which is the quantity normally assigned in applications). Table 1 compares the results of the three methods for  $\nu = 0.5$ ,  $\alpha_B = 60^\circ$  and a range of  $\varepsilon$ . Table 2 gives the values of the deformed edge slope  $\bar{\alpha}_c$  for the "no wrinkle" case of  $\alpha_B = 90^\circ$ . Also included are the corresponding results of the series approach [eqn (35)]. The maximum value of  $\bar{\alpha}_c$  was found to be  $96.66^\circ$  at  $\alpha_B = 90^\circ$  and  $\varepsilon = 0.57$ . For larger values of  $\varepsilon$ , the straightening effect due to the large stretching overcomes the effects of the transverse contraction so that  $\bar{\alpha}_c$  decreases with increasing  $\varepsilon$ .

The results clearly indicate that for small strains the size of the transition region is small  $O(\varepsilon)$ . However, Fig. 4 also shows the substantial increase in its size as  $\alpha_B$  approaches  $\pi/2$ . This is the graphical translation of the change in size from  $O(\varepsilon)$  to  $O(\sqrt{\varepsilon})$  as the height of the wrinkled region decreases. As the strains increase and become moderate to large, the

† Equation (40) was replaced in the numerical algorithm by (39b). The latter yields a quartic polynomial in  $\lambda_\sigma$  which possesses an explicit solution. Its use gave a somewhat better accuracy for the chosen integration step of  $\Delta\alpha = 0.001^\circ$ .

size of the transition region increases, and the “edge effect” type solution deteriorates. It is noted that the use of the asymptotic solution gives good results up to  $\varepsilon \approx 0.05$ . The series solution extends the range up to  $\varepsilon \approx 0.3$ . The implication is that Hooke’s Law can give satisfactory results in some cases which go far beyond its legitimate range of validity. For large values, the full nonlinear constitutive equation must be used.

Large rotations take place in the transition region. Indeed, the angle of the deformed shell at the edge ( $\bar{\alpha}_c$ ) is close to  $\pi/2$  for the whole range of parameters (see Table 2). This suggests a possible linearization in  $\cot \bar{\alpha}$  as a means of simplifying the equations. For example, in the extreme case of  $\bar{\alpha}_c = 96.66^\circ$ ,  $\sin \bar{\alpha}_c = 0.993$ , so that the approximations  $\sin \bar{\alpha} \approx 1$ ,  $\cos \bar{\alpha} \approx \cot \bar{\alpha}$  produce errors of the order of 0.3% which should be acceptable for most applications. With this approximation, the small-strain problem becomes *mathematically linear* in the variable  $y = \cot \bar{\alpha}$ . The differential equation is:

$$(\sin \alpha y_{,x})_{,x} - (\csc \alpha + \varepsilon^{-1})y = -\varepsilon^{-1} \cos \alpha \tag{42a}$$

and the boundary conditions are:

$$y = y_{,x} = 0 \text{ at } \alpha = \alpha_B; \quad y_{,x} = v \csc \alpha \text{ at } \alpha = \alpha_c. \tag{42b}$$

The large-strain problem also simplifies: it is geometrically linear in  $y$ , but materially nonlinear on account of the constitutive relations. The equations are:

$$(\lambda_\theta \sin \alpha)_{,x} = y \lambda_\sigma \tag{43a}$$

$$3\varepsilon y_{,x} = \lambda_\theta - \lambda_\theta^{-3} \lambda_\sigma^{-2} \tag{43b}$$

$$3\varepsilon \csc \alpha = \lambda_\sigma - \lambda_\sigma^{-3} \lambda_\theta^{-2} \tag{43c}$$

with boundary conditions:  $y = y_{,x} = 0$  at  $\alpha_B$ ;  $\lambda_\theta = 1$  at  $\alpha_c$ .

No attempt was made in this paper to incorporate the simplifications into the analysis.

It should be emphasized that, in addition to the large rotations, large variations take place in the circumferential stresses  $N_\theta$  and strains  $e_\theta$  of the transition zone: over a very small distance (in the case of small strains)  $O(\varepsilon)$ ,  $N_\theta$  changes from the value dictated by  $e_\theta = 0$  at  $\alpha_c$  to zero at  $\alpha_B$ , whereas  $e_\theta$  changes from zero at  $\alpha_c$  to that dictated by  $N_\theta = 0$  at  $\alpha_B$ . Thus, the initial estimate for the variation of  $e_\theta$  given by eqn (3) appears to be too weak and should be replaced by the stronger estimate:

$$|e_{\theta,\alpha}| = O(1).$$

Some of the implications will be discussed in the next section.

### CONCLUDING REMARKS

Partial wrinkling with transition zones is a prominent feature of the behavior of many nonlinear membranes, especially near boundaries, stiffeners and other “hard” regions. Many examples exist in biological membranes, inflatable structures and in the limiting behavior (as  $h \rightarrow 0$ ) of buckled plates and shells (so called “tension fields”). Complete solutions to nontrivial problems which are both materially and geometrically nonlinear should, therefore, be of interest, but little published work has been appeared until recently.

Full results can be also useful as a “yardstick” for comparisons with finite element and other purely numerical approaches, which have been developing recently. See, for example, Roddeman (1988).

The spherical barrel was chosen for the more extensive analysis, since wrinkled spherical shells appear in practical applications. An additional feature, due to symmetry, is the *a priori* knowledge of the slope at the interior boundary, which facilitated the analysis as an initial value problem. In this respect, other symmetrical shells of revolution with positive curvature could have been used.

Parameters of the problem which were investigated included: (a) influence of increasing strains on the deterioration of the "edge-effect"; (b) effects of the size of the wrinkled region; (c) effects of the (angular) location of the boundary. Both Hookean and Neo-Hookean materials were used for comparative analysis.

Such investigations should also be useful in understanding the detailed behavior near the edge of the shell. Here, it appears that the size  $O(\varepsilon)$  and properties of the transition zone are different from those encountered in the more typical nonlinear membrane edge effect solutions where the size is  $O(\sqrt{\varepsilon})$ . The large strain gradients and rotations which exist in the transition zone imply the possible strong interaction with local bending effects which are unavoidable near the boundaries. The fact that narrow unwrinkled regions between wrinkles and stiff supports in tension fields are susceptible to premature failure has been demonstrated experimentally, see, for example, Weller *et al.* (1987).

*Acknowledgement*—This research was supported by the Fund for the Promotion of Research at the Technion.

#### REFERENCES

- Libai, A. and Simmonds, J. G. (1988). *The Nonlinear Theory of Elastic Shells*. Academic Press, Boston.
- Roddeman, D. G. (1988). Force transmission in wrinkled membranes. Doctorate Thesis, The Technical University, Eindhoven, The Netherlands.
- Roddeman, D. G., Drukker, J., Oomens, C. W. J. and Janssen, J. D. (1987). The wrinkling of thin membranes: Part I—theory; Part II—numerical analysis. *ASME J. Appl. Mech.* **54**, 884–892.
- Steigmann, D. J. (1989). Tension field theory. Department of Mechanical Engineering, University of Alberta, Report No. 69.
- Steigmann, D. J. and Pipkin, A. C. (1989). Axisymmetric tension fields. *ZAMP* **40**, 526–542.
- Weller, T., Kollet, M., Libai, A. and Singer, J. (1987). Durability under repeated buckling of stiffened shear panels. *AIAA J. Aircraft* **24**, 6–7.
- Wu, C. H. (1978). Nonlinear wrinkling of nonlinear membranes of revolution. *J. Appl. Mech.* **45**, 533–538.
- Zak, M. (1982). Statics of wrinkling films. *J. Elasticity* **12**, 51–63.